

FIXOUT PROCEDURES



TOOLS REQUIRED

Screw gun and drive bits (Phillips or square drive depending on screws).

Alternatively nail guns for steel are available in the market - 30mm-50mm nails purpose made for shooting to steel up to 0.75mm gauge.

DOOR JAMBS

Ensure jambs are installed with packing to allow the job to be plumbed correctly in position.

ARCHITRAVES

Nail architraves to door jambs and window reveals. The architrave may be fixed to the stud using threaded and drill point screws or purpose made nail gun if required.

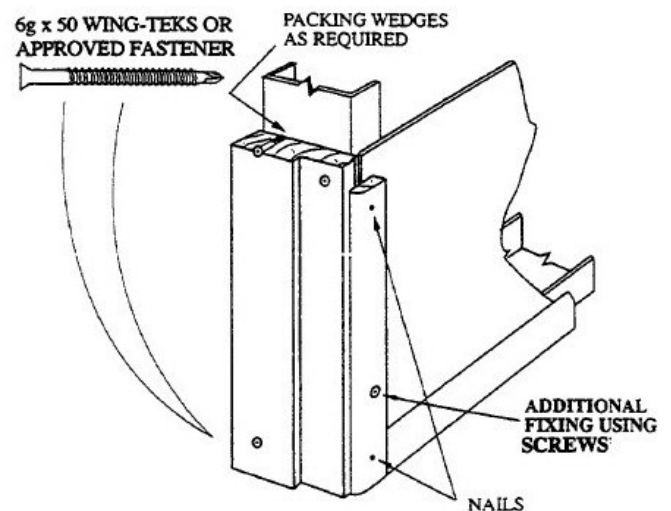

Fixing Door Jambs & Architraves.

SKIRTING BOARDS

Screw skirting to steel framing. If either a pilot hole is drilled through skirting boards before installing screws, or alternatively, if wafer screws are used, it will help prevent a thread being formed in the skirting and pulling away from the wall during fixing.

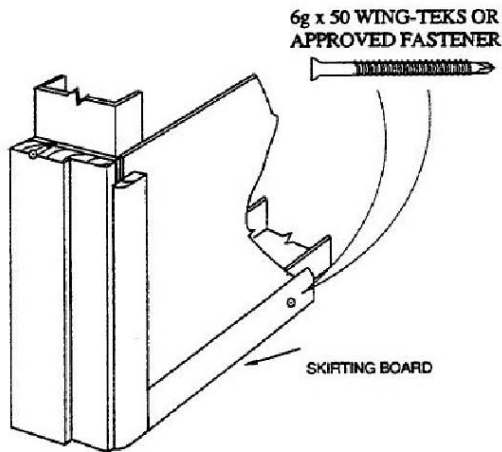

Fixing Skirting Boards

CUPBOARD FIXING RAIL

Use countersunk self drilling screws of appropriate length to fix cupboard rail to steel frame.

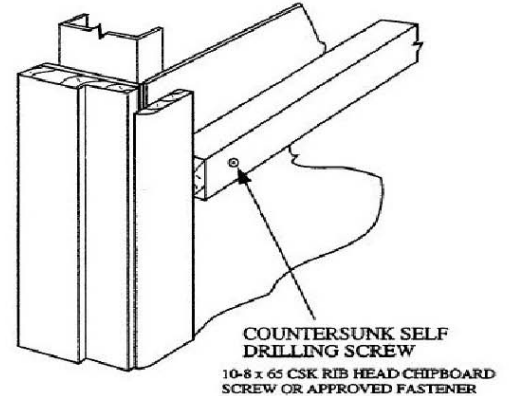

Fixing Cupboard Rail

For further information please contact:

National Association of Steel-Framed Housing Incorporated
17-19 Gladding Place, PO Box 76-134, Manukau City

Phone: (09) 262 1625
Toll free: 0800 333 225

Fax: (09) 262 2856
Email: gm@nashnz.org.nz

V1.2 28.4.06

IMPORTANT

This publication is designed to assist Qualified tradespersons in the fixing of materials to steel framed houses and is not intended for use by untrained personnel. The recommendations are a guide only. All fixing should be in accordance with manufacturers Specifications.

The information contained in this literature is correct at the time of printing. However, it is subject to change without notice.